

Adders on a basis of piezoceramic transformers

V. Sharapov¹, R. Kažys², A. Vladišauskas², K. Bazilo¹, D. Romanenko¹

¹ – Cherkasy State Technological University, Shevchenko str., 460, Cherkasy, Ukraine

e-mail: v_sharapov@rambler.ru

² – Kaunas University of Technology, Studentu56-350, LT-51424 Kaunas, Lithuania

crossref <http://dx.doi.org/10.5755/j01.u.66.1.265>

Abstract

In article the constructions of adders on the basis of disk monomorphic and cylindrical piezotransformers are proposed and investigated.

Keywords: piezoceramic transducer, adder, dynamic characteristics.

Introduction

Piezoceramic transducers are widely applied in hydro acoustics, electro acoustics, ultrasonics, medical, applications measuring technics and in other areas of science and technology [1-3].

One of the widespread and necessary units in construction of the elements of automatic systems, differential schemes are the adders. Besides, such devices are capable to carry out a role of link elements in the configuration of the large dielectric chips. And it is either absolutely independent element, or a part of the integrated piezoelectric device volume where there is an addition or subtraction of stationary or non-stationary processes takes place [4].

Problem and approach

As it is known, application of the sinusoidal electric field to a piezoelectric material due to piezoeffect there are direct and back propagating waves of displacement, deformation and pressure which in a stationary mode give a standing wave. It is natural that if to excite some running waves in the volume of the piezoelectric material we will receive algebraic addition of the energy streams at each point of the excited volume [4, 5].

The output signal is obtained from a piezoelement volume by means of an output electrode on which at the expense of direct piezoeffect the charge proportional to a total value of a mechanical pressure, acting on an electrode operating in the field of an arrangement is induced.

One construction of the adder is presented in Fig.1. According to the operating mode it represents the piezoelectric transformer of the cross-section type [4].

The summation of two pressures of identical frequency ω $U_{in1} = U_{m1} \sin(\omega t + \varphi_1)$ and $U_{in2} = U_{m2} \sin(\omega t + \varphi_2)$ on a piezoelement which is presented in Fig. 1, we will get:

$$U_{out} = k_1 U_{in1} + k_2 U_{in2} = U_m \sin(\omega t + \varphi), \quad (1)$$

where

$$U_m = \sqrt{k_1^2 U_{m1}^2 + k_2^2 U_{m2}^2 + 2U_{m1} U_{m2} k_1 k_2 \cos(\varphi_2 + \varphi_1)}, \quad (2)$$

$$tg \varphi = \frac{k_1 U_1 \sin \varphi_1 + k_2 U_2 \sin \varphi_2}{k_1 U_1 \cos \varphi_1 + k_2 U_2 \cos \varphi_2}. \quad (3)$$

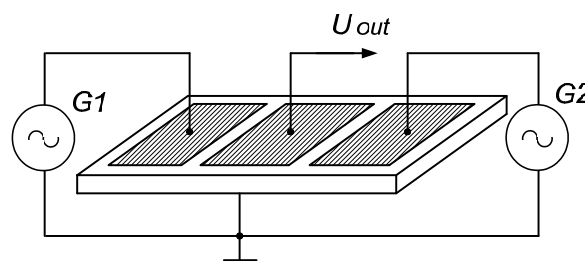

Figs.1. Piezoceramic adderr

Here k_1 and k_2 are the factors defining relationship of the pressure between an output and each of the inputs. Values of these factors are defined by geometry of these electrodes and material parameters at the chosen mode of vibration (mechanical Q-factor, coefficient of the electromechanical coupling, piezomodule etc.). For the elementary constructions of the summarizing transformers (rods, plates, disks) values of the factors k_1 and k_2 will be defined by [4]:

$$k_1 = p \frac{A_1}{A} \quad \text{and} \quad k_2 = p \frac{A_2}{A}, \quad (4)$$

where A_1 , A_2 , A are the areas of input and output electrodes; p is the constant for the given constructions and a material of the adder factor; at certain parameters of the adder factors k_i can have the values essentially exceeding unit.

Practical interest is represented by cases, when $\varphi_1 - \varphi_2 = 0$ or $\varphi_1 - \varphi_2 = \pi$. In these cases

$$U_m = \sqrt{k_1^2 U_{m1}^2 + k_2^2 U_{m2}^2 \pm 2U_{m1} U_{m2} k_1 k_2} = k_1 U_{m1} \pm k_2 U_{m2}. \quad (5)$$

For a symmetric construction). Thus,

$$U = k(U_{m1} \pm U_{m2}). \quad (6)$$

For n inputs, using an induction method, we will receive:

$$U_m = \left[k_n^2 U_{nm}^2 + 2k_n U_{nm} k_{1,2,3...(n-1)} U_{1,2,3...(n-1)} \times \right. \\ \left. \times \cos(\varphi_m - \varphi_{1,2,3...(n-1)}) + k_{1,2,3...(n-1)}^2 U_{m1,2,3...(n-1)}^2 \right]^{1/2} \quad (7)$$

$$\operatorname{tg} \varphi = \frac{k_n \sin \varphi_n + k_{1,2,3...(n-1)} U_{m1,2,3...(n-1)} \sin \varphi_{1,2,3...(n-1)}}{k_n U_{nm} \cos \varphi_n + k_{1,2,3...(n-1)} U_{m1,2,3...(n-1)} \cos \varphi_{1,2,3...(n-1)}}, \quad (8)$$

where $U_{m1,2,3...(n-1)}$ and $\varphi_{1,2,3...(n-1)}$ are defined under formulas through $U_{m1,2,3...(n-2)}$ and $\varphi_{1,2,3...(n-2)}$ etc. Thus

$$k_i = p \frac{A_i}{A}. \quad (9)$$

One of the basic parameters of the piezoceramic adders effective work is the transfer coefficient of the electric signal. The transfer coefficient of the adders is a ratio of the maximum amplitude of the input signal to the maximum amplitude of one of the summable signals [6].

The objective of this research is investigation of influence of the schemes of connection on the transfer coefficient of the piezoceramic adder.

Results

Authors have investigated two types of the piezoceramic adders – disk and cylindrical.

According to Eq. 1 the output voltage U_{out} obtained from the adder, is the sum of the input voltage increased by factor of transformation. Hence, for studying of behavior of the adder we will consider each of the composed expressions (1). In the case of only one input the piezoceramic adder behaves as a piezoceramic transformer. Then, knowing behavior of the piezotransformer at the resonant frequency, an in the frequency range around it, it is possible to predict behavior of the piezoceramic adder.

For carrying out experimental investigation the disk piezotransformer (Fig. 2) from piezoceramics ИТС-19 (analogue PZT-5A) with the diameter 30 and thickness of 0,8 mm was manufactured. Electrodes on the surfaces of a piezoelement have been divided into five parts – the central disk 5 (5') and the external ring consisting of four equal parts 1-4 (1'-4').

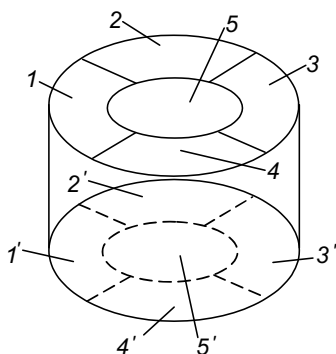

Figs.2. Disk piezotransformer

Measurements of the amplitude-frequency responses (AFR) were carried out in a piezotransformer mode

applying of the sinusoidal electric voltage from the generator G3-106 ($U = 1$ V) on the electrodes 1-1'. The output signal was taken off from the electrodes 5-5' by means of the millivoltmeter V3-38 (the traditional scheme Tr-Tr [3]) and from the electrodes 5-1' (the scheme Tr-DD [3]).

Results of AFR measurements are shown in Fig. 3.

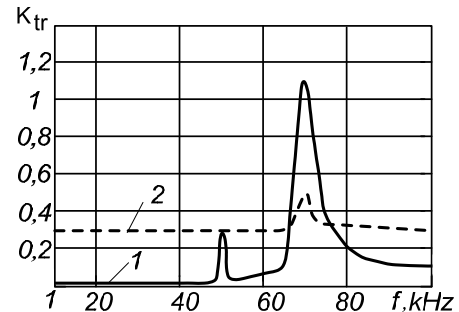

Fig. 3. Amplitude-frequency responses of the piezotransformer: 1 – traditional scheme; 2 – scheme Tr-DD

The influence of the area of electrodes, on which the input voltage was submitted and on the transfer coefficient of the piezotransformer at the resonant frequency f_r , up to resonant f_{ur} and after resonant f_{ar} region were investigated also. For measurements the traditional scheme of the connection was used.

Results of measurements are presented in Table 1.

Table 1. Transfer coefficient of a piezotransformer

Electrodes		K_{tr}		
Input	Output	f_{ur}	f_r	f_{ar}
1-1'	5-5'	0,004	1,1	0,100
1+2-1'+2'	5-5'	0,006	2,2	0,195
1+2+3-1'+2'+3'	5-5'	0,010	3,0	0,265
1+2+3+4-1'+2'+3'+4'	5-5'	0,013	4,1	0,310

From Table 1 it follows that the increase in the area of input electrodes leads to the increase in factor of the transfer coefficient of the piezotransformer.

Research of the piezotransformer has also shown that a shift of phases between input and output signals is 0° in an up to the resonant region, 90° at the resonance and 180° in after the resonant region.

Influence of the consecutive connection of parts of the piezotransformer on the transfer coefficient on the resonant frequency is investigated also. For measurements the traditional scheme of the connection of the piezotransformer was used. The maximum output voltage was measured by means of the oscilloscope C1-55. Results of the measurements are given in Table 2.

From Table 2 it follows that the biggest output voltage of the piezotransformer can be obtained at its connection under the scheme № 4.

As it was already marked, this information can be used at constructing piezoceramic adders.

Table 2. The output voltage of the piezotransformer

№	Electrodes		U _{outs} , V
	Input	Output	
1	1-1'	2-2'	2,0
2	1-1'	3-3'	2,2
3	1-1'	4-4'	1,8
4	1-1'	5-5'	4,6
5	1-1'	2+3+4- 2'+3'+4'	2,3
6	1-1'	2+5+4- 2'+5'+4'	3,1

For investigation of adders traditional scheme of the adder connection (Fig. 4) and the scheme Tr-DD-Tr were used (Fig. 5) [7].

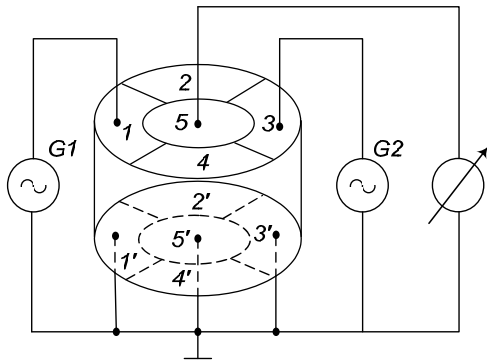

Fig. 4. Traditional scheme of the adder connection

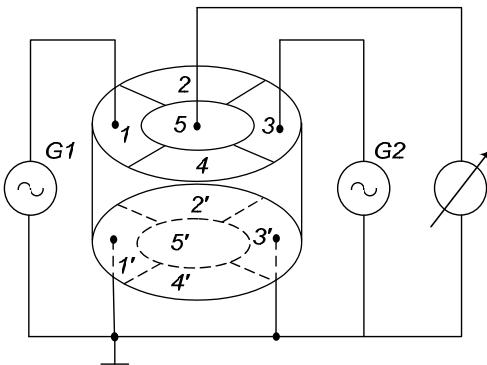

Fig. 5. Adder connection under the scheme Tr-DD-Tr

The piezoceramic adder contains two generators of the electric oscillations G1 and G2, and a disk type monomorphic piezotransformer (Fig. 1).

When carrying out the experiments the following means were used: the generator G3-106, the oscilloscope C1-55 and the millivoltmeter V3-38. Measurements were carried out using applying on the adder of sinusoidal electric voltage (U = 1 V) [7].

The results of measurements are given in Table 3 and in Fig. 6.

Table 3 shows the maximum output voltage of the adder depending on the scheme of connection of electrodes.

From Table 3 it is visible that adder connection under the scheme Tr-DD-Tr (the scheme № 3, 4) leads to increased output voltage in an up to the resonant and after the resonant areas.

Table 3. Output voltage of the adder on the basis of disk monomorphic piezotransformer

№	Connection scheme	U _{outs} , V		
		f _{ur}	f _r	f _{ar}
1		0,02	8,10	0,60
2		0,05	13,5	0,90
3		0,80	3,50	1,10
4		1,20	5,60	1,50
5		0,04	13,0	0,80

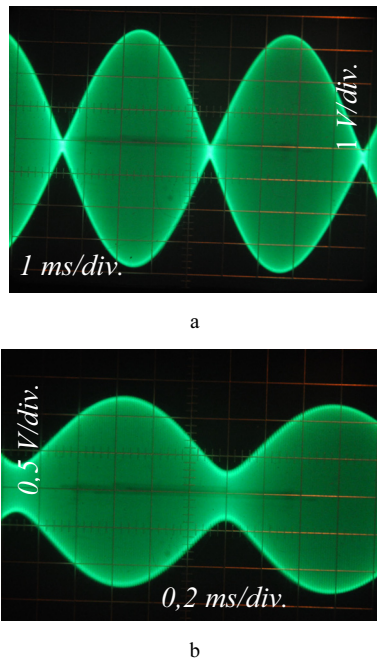

Fig.6. The summator oscillograms: a - traditional scheme; b - scheme Tr-DD-Tr

The investigation of the adder was also carried out on the cylindrical sample. For this purpose the piezotransformer with the radial polarization, which is made from the piezoceramics LiTC-19 (analogue PZT-5A), in the shape of the cylinder with the external diameter 32 mm, the internal diameter 28 mm and the height 20 mm. The internal and external electrodes of the piezoelement have been divided into 6 equal parts. The construction of the cylindrical piezotransformer is shown in Fig. 7.

For adder research the traditional scheme of connection was used (Fig. 8).

The piezoceramic adder contains two generators of the electric oscillations $G1$ and $G2$ and the cylindrical polyelectrode piezotransformer.

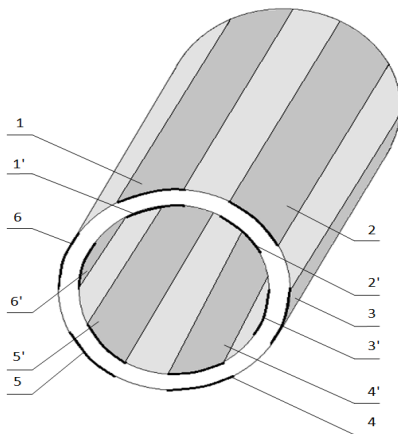

Fig.7. The construction of the polyelectrode cylindrical piezotransformer: 1-6, 1'-6' – electrodes

When carrying out experiments the following means were used: the generator G3-106, and the oscilloscope C1-55. The measurements were carried out applying to the adder sinusoidal electric voltage ($U = 3 \text{ V}$).

The results of measurements are presented in Table 4 and in Fig. 9.

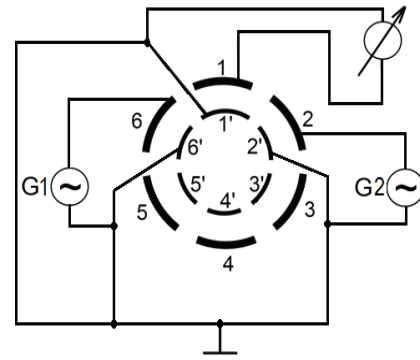

Fig.8. The traditional scheme of connection of the cylindrical summator

Table 4. The transfer coefficient of the cylindrical adder

№	Electrodes			K_{tr}		
	G1	G2	Output	f_{ur}	f_r	f_{ar}
1	2-2'	6-6'	1-1'	0,13	12,4	1,1
2	2-2'	5-5'	1-1'	0,11	7	0,78
3	4-4'	6-6'	1-1'	0,07	7	1,85
4	5-5'	6-6'	1-1'	0,08	7,2	0,67

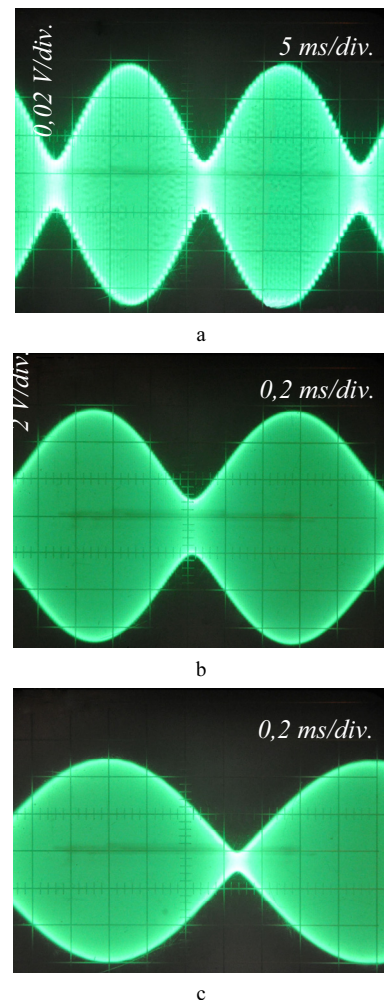

Fig. 9. The oscillograms of the cylindrical adder (Table 4, scheme 1): a - at f_{ur} ; b - at f_r ; c - at f_{ar}

From Table 4 it follows that the biggest transfer coefficients of the piezosummarator can be obtained at its connection under the scheme № 1.

Conclusions

1. The summators on the basis of monomorphic disk and cylindrical piezotransformers were developed and investigated.

2. The use of the developed adders has allowed to increase level of the output voltage.

3. The obtained results can be used in constructing of the low-frequency hydroacoustic transducers.

References

1. **Domarkas V., Kažys R.-J.** Piezoelectric transducers for measuring devices. Vilnius: Mintis.1974.P. 258. (in Russian).
2. **Kažys R.-J.** Ultrasonic information measuring systems. Vilnius: Mokslas. 1986. P. 216 (in Russian).
3. **Sharapov V. and others.** Piezoelectric sensors. Under red. V. Sharapov. Moscow: Technosphere.2006. P. 632 (in Russian).
4. **Pluzhnikov V., Semenov V.** Piezoelectric firm schemes. Moscow: Energy. 1971 (in Russian).
5. Piezoceramic transformers and sensors. V. Sharapov, K. Bazilo and others. Cherkasy: Vertical. 2010. P. 278 (in Russian).
6. **Lavrinenko V.** Piezoelectric transformers. Moscow: Energy. 1975. P. 112 (in Russian).
7. Patent of Ukraine № 49918. G06C 15/00, G06F 7/00 from 22.01.2010. Piezoceramic adder. V. Sharapov, K. Bazilo and others.

V. Sharapov, R. Kažys, A. Vladišauskas, K. Bazilo, D. Romanenko

Pjzokeramikos transformatorių pagrindu veikiančios sumatoriai

Reziumė

Sukurti ir išbandyti diskiniai ir cilindriniai pjzotransformatoriai, kurie naudojami kaip įtampos transformatoriai. Šių transformatorių efektyvumas priklauso nuo pjzomedžiagos parametrų, elektrodų geometrijos ir pjzokeitiklių virpesių tipo (mechaninės kokybės, elektromechaninio ryšio koeficiento, pjzomodulio ir t. t.).

Eksperimentai buvo atlikti naudojant disko formos pjzotransformatorių, pagamintą iš CTS-19 pjzokeramikos, ir išmatuotos dažninės amplitudės charakteristikos. Tyrimų rezultatai parodė, kad didesnio ploto įėjimo elektrodai padidina pjzotransformatoriaus perdavimo koeficientą. Fazių poslinkis tarp įėjimo ir išėjimo signalų sudaro 0° prieš rezonansą, 90° rezonanso metu ir 180° po rezonanso.

Pateikta spaudai 2011 02 09