

# Ultrasonic non-destructive testing system of journal bearings

R.Kažys, L.Mažeika, A.Voleišis, R.Šlīteris, K.Kundrotas, V.Augutis

Prof. K.Barðauskas Ultrasound Research Center

\*Department of Electronic Instruments

Kaunas University of Technology

## Introduction

Delaminations or poor adhesion between babbitt and main metallic core of bimetallic journal bearings is one of the reasons deteriorating reliability of turbines. For this purpose various ultrasonic non-destructive testing (NDT) techniques can be exploited [1]. The principle of testing is based on the influence of adhesion quality on the amplitude of the ultrasonic signals reflected by the interface babbitt layer/ metal. They enable to detect defective zones and to measure their area. However, a big variety of the diameters of bearings, the complicated shape of the interface between the babbitt layer and main metallic core makes the manual NDT not efficient. The objective of this paper is to present the completely automatic ultrasonic system for NDT of bimetallic plain and journal bearings.

## Theory

Detection and estimation of delaminated zones in bearings is based on the measurements of the reflection coefficient  $K_{bm}$  of ultrasonic waves at the boundary babbitt/ metal. Experiments show that variations of the reflection coefficient  $K_{bm}$  in the case of good adhesion are  $0.22 \div 0.24$  for the core made from brass and  $0.29 \div 0.31$  for the steel core. When the delamination takes place  $K_{bm} \rightarrow 1$ . Let us analyze possible ways to evaluate the reflectivity of the boundary babbitt/ metal.

Taking into account that the curvature radius of bearings usually is bigger than the distance between their inner surface and the ultrasonic transducer, it is possible to model the bearing as a set of plane layers (Fig.1).

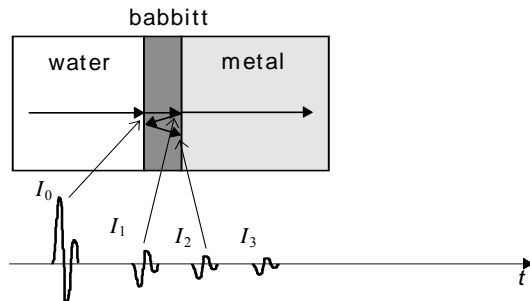

Fig.1. Analyzed structure water-babbitt-metal and reflected ultrasonic pulses

Due to mismatch of acoustic impedances multireflections of ultrasonic pulses inside the babbitt layer take place. In Fig.1  $I_0$  is the amplitude of the pulse

reflected by the interface water - babbitt,  $I_1, I_2, I_3 \dots$  are the amplitudes of the multireflected pulses in the babbitt layer. Corresponding coefficients for these pulses can be expressed in terms of acoustic impedances and are equal

$$K_0 = K_{wb}^R,$$

$$K_1 = K_{wb}^T \cdot K_{bm}^R \cdot K_{bw}^T,$$

$$K_i = K_{i-1} \cdot K_{bm}^R \cdot K_{bw}^R, \quad i = 2, 3, \dots$$

where superscripts denotes reflection (R) or transition (T), subscripts - material and direction (e.g. 'wb' - water/babbitt). The values of these coefficients are presented in Table 1. Acoustic impedances are taken from [2] and are for babbitt  $24.8 \cdot 10^6$  kg/m<sup>2</sup>s, brass -  $36.64 \cdot 10^6$  kg/m<sup>2</sup>s, steel -  $46.02 \cdot 10^6$  kg/m<sup>2</sup>s.

Table 1. The values of the reflection coefficients  $K_i$  in the good adhesion and the delamination cases

	Reflected pulse number				
	0	1	2	3	4
Good adhesion					
Brass	0.9225	0.0287	-0.0080	0.0022	-0.0004
Steel	0.9225	0.0449	-0.0125	0.0035	-0.0006
Delamination					
no diff.	0.9225	-0.1490	-0.1375	-0.1268	-0.1170

From the data presented in Table 1 follows that in the case of delamination the pulses reflected inside the babbitt layer are decaying much less. The second difference is that the pulses reflected by a delamination are of an opposite polarity than the pulse reflected by the inner surface of a bearing. In the case of a good adhesion only even multireflected signals are of the opposite polarity.

The reflection coefficient  $K_{bm}^R$  can be expressed in terms of the ratio of the pulse amplitudes  $I_0, I_1$  or  $I_1, I_2$ . In the first case

$$K_{bm}^R = \frac{I_1}{I_0} \cdot \frac{1}{K_{wb}^T \cdot K_{bw}^T \cdot K_{wb}^R},$$

assuming that  $K_{wb}^T, K_{bw}^T, K_{wb}^R$  are measured beforehand.

In the second case

$$K_{bm}^R = \frac{K_2}{K_1} \cdot \frac{1}{K_{bw}^R},$$

where  $\frac{K_2}{K_1}$  can be evaluated as the ratio of the pulse amplitudes  $\frac{I_2}{I_1}$  and the reflection coefficient  $K_{bw}^R$  is also measured beforehand.

Of course, if only the amplitude will be taken into account in both cases we shall lose the information about the sign of the reflection coefficient. Hence, the reflectivity of the interface babbitt/ metal can be evaluated from the measured ratios of the amplitudes of ultrasonic pulses reflected inside the babbitt layer and the coefficients  $K_{wb}^T, K_{bw}^T, K_{wb}^R$ .

**Evaluation of the delamination area**

The minimal detectable area, coverage and accuracy of a total delamination area evaluation are critical parameters in NDT of bearings.

The minimal detectable delamination area depends on the ultrasonic beam crosssection area at the boundary babbitt/ metal. If the area of delaminated zone is less than the beam crosssection area, the total reflected signal is the result of interference of the signals reflected from delaminated and perfectly bonded zones. In this case the amplitude of the reflected signal can be obtained from the integral reflection coefficient

$$K_{\Sigma}^R = S_D \cdot K_1^d + (S_B - S_D) \cdot K_1, \tag{4}$$

where  $S_D$  is the delamination area in the beam crosssection region,  $S_B$  is the total ultrasonic beam crosssection area,  $K_1^d$  is the total reflection coefficient in the case of delamination,  $K_1$  is the total reflection coefficient for the pulse reflected by the boundary babbitt/metal. Note, that the reflection coefficients  $K_1^d$  and  $K_1$  can be positive or negative depending on the acoustic impedances of media at the particular point of the boundary. The dependence of the  $K_{\Sigma}$  from the ratio of delaminated and perfectly bonded covered by an ultrasonic beam is presented in Fig.2.

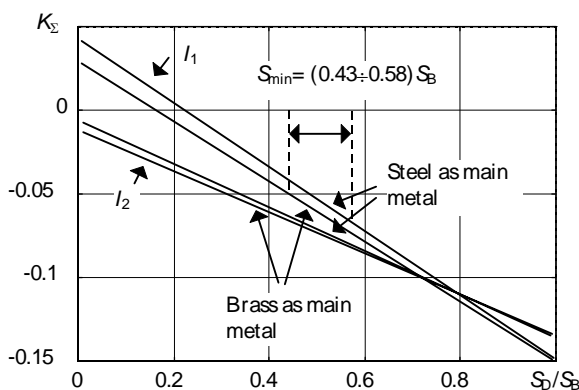

Fig.2. The dependence of the integral reflection coefficient from the ratio of delaminated area and ultrasonic beam crosssection area

The minimal detectable area can be determined setting threshold level equal to  $2I_1$  for the first reflected pulse  $I_1$  when a polarity of the signal is not taken into account. The

minimal detectable area in this case will be approximately  $0.58S_B$ . Using the second reflected signal  $I_2$  the sensitivity can be higher and, correspondingly, minimal detectable area is approximately  $0.2S_B$ . When the delaminated area covers only a part of the beam crosssection region the amplitude of the first reflected pulse  $I_1$  can be less than the amplitude of the second reflected pulse  $I_2$ . This can be used as an indication that the delaminated zone does not cover the beam crosssection completely.

A coverage can be evaluated taking into account that in the case of a disk transducer the ultrasonic beam spot on the boundary has a circular shape with the diameter very close to the diameter of transducer. So the maximal scanning step allowing to cover a whole surface of a bearing is equal to  $\sqrt{3}d_t$ , where  $d_t$  is the transducer diameter.

The most conservative approach in the calculations of a total delamination area is to assume that at each scanner position, where the delamination was detected, the area of the delamination is equal to the area of the rectangle with the sides corresponding to scanning steps in both directions.

In order to achieve a higher accuracy of the estimation of delaminated areas it is necessary to perform scanning with a smaller step and to take into account that on the delamination edges only a part of ultrasonic beam crosssection is covered by the delamination zone[2].

**Structure of the system**

The developed ultrasonic system for NDT of journal bearings consists of the electronic unit, the scanner, the testing tank, set of the ultrasonic transducers and IBM PC type computer with a specialized software. The structure of the system is presented in Fig.3.

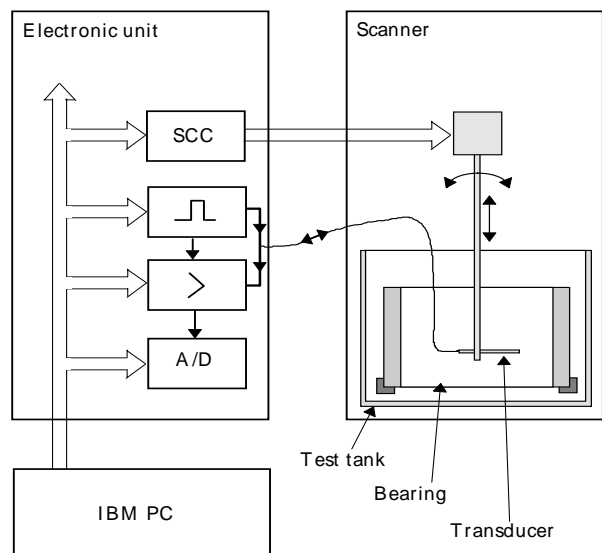

Fig.3. Structure of ultrasonic system for NDT of journal bearings

The electronic unit consists of the pulse generator, the amplifier, the high speed data acquisition card with the 40MHz A/D converter, the scanner control card (SCC) and

the special parallel interface for communication with the computer power supply block.

The two coordinate scanner possess two stepping motors. The minimal scanning step in the vertical direction along the axis of a bearing is 0.1mm and around the circumference is 1.8°.

The test tank filled with water is used to place bearings during testing. The tank has special holders and centering mechanism enabling positioning of the bearings with an accuracy about 1 mm.

Heavily damped ultrasonic transducers with the central frequency 10MHz and the diameter 5mm are used for radiation and reception of short ultrasonic pulses. The duration of emitted ultrasonic signals is about one period.

The original software have been developed to control the whole testing process. It is implemented in multiwindows mode enabling to create a convenient user interface form. The test results can be presented in the usual A,B,C scan modes with a selected option of signal processing. The bearing testing report contains a spatial distribution of delaminated zones and their total area .

### Examples of testing data presentation

The 280mm diameter bearing with a thin (approximately 0.5mm) layer of babbitt was investigated with a purpose to evaluate a performance of the NDT system.

The test results are presented in Fig.4 and 5.

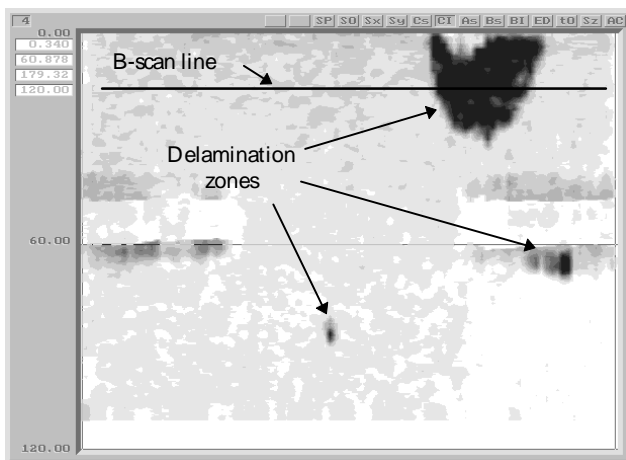

Fig.4. C-scan image of the bearing with delaminated zones denoted as dark areas

Fig.4 shows the C-scan image of the bearing. The dark areas correspond to delamination zones. There is one large defective zone near the upper edge of the bearing which shows that this bearing can not be used. The few smaller delaminated spots, shown in the middle of the image, most likely occurred during manufacturing of the bearing. The

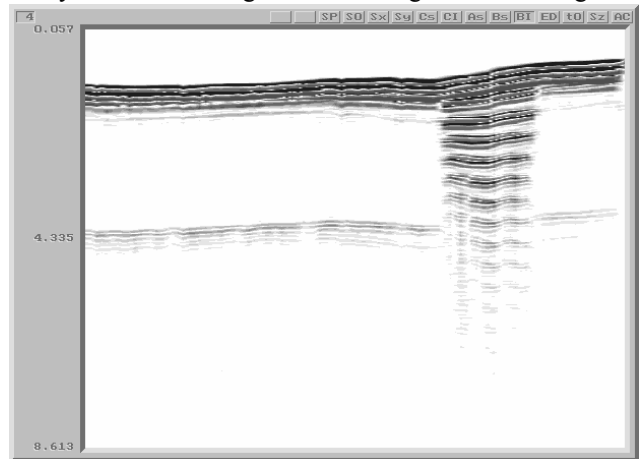

Fig.5. B-scan image of the bearing containing delaminated zones. At these zones long reverberations of the signal inside the babbitt layer exist. Location of the B-scan is shown in Fig.4

B-scan presented in Fig.5 indicates typical reverberations in the babbitt layer in the case of delamination.

### References

1. **Krautkramer J., Krautkramer H.** Ultrasonic testing of materials. Springer- Verlag, Berlin- Heidelberg, 1983.
2. **Ndestructive Testing Handbook**, 2nd edition, vol.7. Ultrasonic Testing/ Albert S.Birks, Robert E. Green, Paul McIntire.- USA: American Society for Nondestructive Testing, 1991.
3. **Smith R.A.** Ultrasonic defect sizing in carbon-fiber composites -an initial study, INSIGHT, Vol.36, No.8, 1994, pp.595-605.

R.Kažys, L.Mažeika, A.Voleišis, R.Šliteris, K.Kundrotas, V.Augutis

### Ultragarsinė slydimo guolių neardančiosios kontrolės sistema

#### Reziumė

Aprašoma automatinės ultragarsinės slydimo guolių kontrolės sistemos struktūra, darbo principai ir praktiniai matavimo rezultatai. Sistemos darbo principas pagrįstas ultragarsinių signalų atspindžio nuo babito ir metalo ribos savybių pokyčiu esant sluoksniavimuisi. Matavimai atliekami impulsiniu režimu, imersiniu variantu, skenuojant visą vidinį guolio paviršių. Aprašomas teorinis metodo pagrindimas, tikslumas bei defektinio ploto įvertinimo kriterijai. Pateikiama guolio tyrimo pavyzdžių.